

Overdrive Controller ODC2321

This document is identical to previous publications on overdrive controllers (ODC) except for the circuit and its description. The improvement concerns the simpler function with operation by an illuminated pushbutton, which replaces the toggle switch on the dashboard. The push button fits into the hole of the toggle switch.

This ODC can be used for Laycock overdrives type LH (in MGBs from 1968 on).

Introduction

By default the overdrive is operated by a (toggle) switch. If you forget to switch off the OD when you leave the 3rd/4th gear, the overdrive is automatically switched on again when you shift up to the 3rd/4th gear, which is mostly undesirable. To prevent this, I have built a small electronic box, which is extremely easy to install without changing the existing wiring.

Therefore the original state can be restored within seconds. The two 6.3mm Fastons (wires yellow and white) are disconnected at the toggle switch and connected to the pre-assembled illuminated pushbutton. For the light function (optional), an additional stranded wire (violet/yellow) must be added.

Function

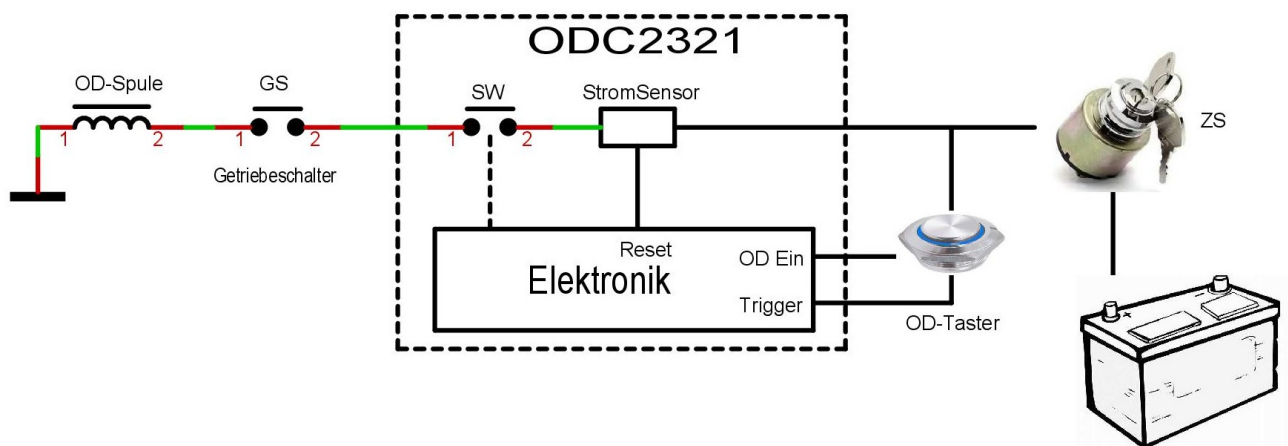

The overdrive (OD) can only be engaged in 3rd and 4th gear to prevent destruction due to excessive torque in 1st and 2nd gear. This is achieved by a switch (GS) mounted on the gearbox, which is only actuated in 3rd and 4th gear. This is electrically in series with the actuating coil (OD-Spule) of the overdrive. The overdrive controller can be seen as an additional switch in series, which closes when the overdrive is engaged and opens when the transmission switch (GS) opens.

If the push button (OD-Taster) is pressed in 3rd/4th gear, the overdrive switches on (SW) and the ring on the push button lights up (OD Ein). The current sensor detects the coil current. Pressing again switches the overdrive off again (Trigger), the lamp goes out.

If the 3rd/4th gear is left, the GS opens, the current sensor detects this and switches the ODC off via Reset and remains in this state, even if the 3rd or 4th gear is engaged again.

Overdrive Controller ODC2321

Installation

A white stranded wire (+Ign) leads to the overdrive switch/button (and to the fuel pump) and comes as switched +12V (stranded wire yellow) in the wiring harness first back to the engine compartment and is there connected via a round "bullet connector" to the stranded wire (red/yellow) of the transmission switch. This connection is opened and the overdrive controller is connected according to the wire colors. There is one (black) connection to ground and optionally one stranded wire (violet/yellow) to the push button. The following photos show the simple installation in a MGB.



Original Wiring



ODC2321 built in

Overdrive Controller ODC2321

Circuit

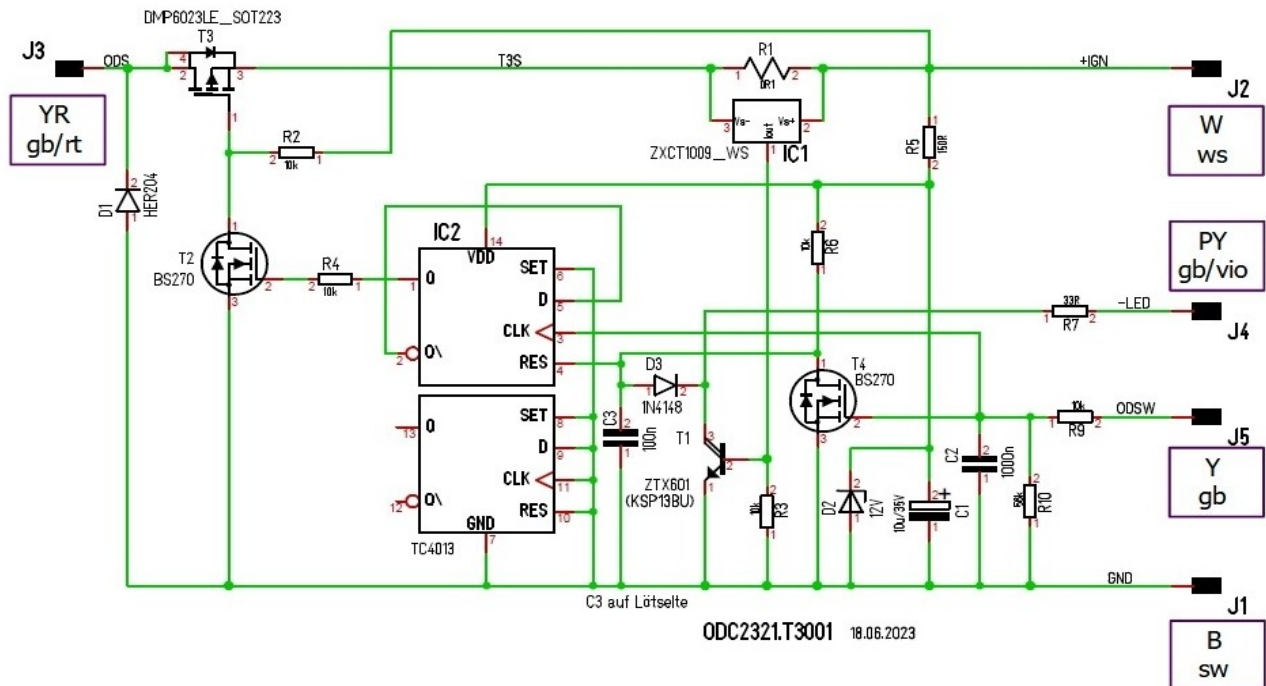

The circuit consists of a power MOSFET T3 as a switch ("relay contact") and R1/IC1 to detect the current, and as the heart of the circuit IC2. At J5 is the signal from the illuminated pushbutton and switches IC2. IC2 is reset upon powerup (T4 and T1 off) via the RES input.

At J2 there is +Ign (white wire) and in the ON state it is passed on to the gear switch via T3 at J3 (red/yellow wire). If the push button (at J5) is pressed, the reset is cancelled via T4 and IC2 is switched over and T3 is switched on by means of T2, thus the overdrive coil is supplied with current. The current flowing through R1 is converted to a proportional current in IC1, which turns on transistor T1, which in turn prevents IC2 from being reset, and the signal LED in the illuminated pushbutton is turned on via J4 through the limiting resistor R7.

If the current flow is interrupted by the gear switch (leaving the 3rd/4th gear level), transistor T1 switches off. This enables the reset, resets IC2 and turns off the power MOSFET T3.

The capacitor C1 and the Zener diode D2 limit and smooth the +12V supply voltage of IC2.

At J1 (black wire) a connection to the chassis is necessary.

Overdrive Controller ODC2321

Connections

J1 Ground, black; Bullet Male

J2 +Ign, white; Bullet Male

J3 to OD, yellow/red; Bullet Female **

J4 to signal lamp in pushbutton, violet/yellow;
round coupling 4mm (red)

J5 from push button, yellow

Overdrive Controller ODC2321

B Ground (neg.)

W +Ign

YR Solenoid

PY -LED

Y OD Switch

** compressed (to Dia 4.7mm) round coupling (blue)

Pre-assembled illuminated pushbutton

Mounting diameter: 12mm

Two thin washers M12x16 are used (not shown).

Pushbutton color: chrome or black

Illuminated ring: green, yellow, blue, red, white

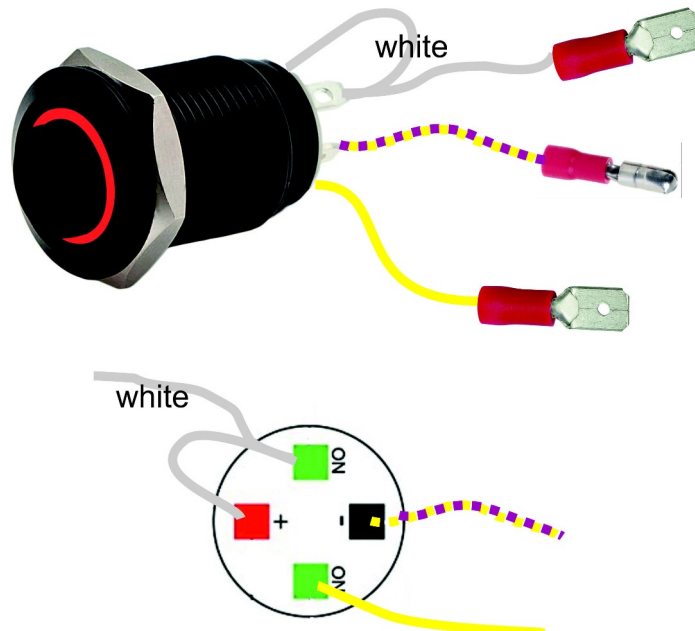

Overdrive Controller ODC2321

PCB Layout

This version (ODC2321) is intended for a (small) series production. A pre-series has been built, see photo on the right.

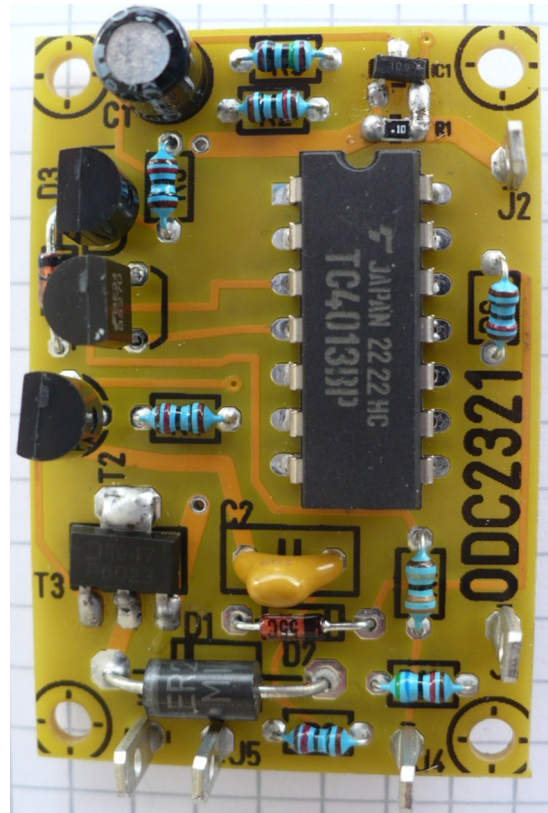
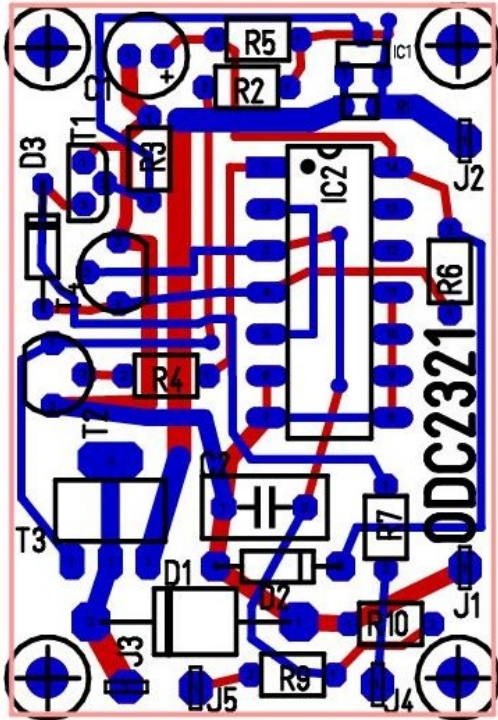

The PCB layout is optimized for installation in a Hammond 1551RFL enclosure [CONRAD 534305].



Encloser

Finally

The circuit is freely usable for a reproduction without commercial purpose. A parts list with suppliers and prices (material costs approx. Euro 15.--), PCB, kit as well as CAD documents can be obtained from the author.

This description and further documents can be found on the homepage <https://www.swiss-mgb.com/allerlei-zu-kaufen/overdrive-controller/>.